

Cartouches à Vide

VACUUM LINE
by **DBI**



Vacuum Solutions Supplier
www.air-best.com

AIRBEST

*FOURNISSEUR DE SOLUTIONS
POUR LE VIDE*



Fonctions

- Compacte - Facile à entretenir
- Différents niveaux de vide et de débits aspirés convenant à tous les besoins
- Plusieurs types de cartouches à vide offrant une plus grande personnalisation selon l'application
- Supports et silencieux en option

Applications

- Industrie automobile
- Industrie du bois
- Industrie du métal
- Industrie agro-alimentaire
- Industries en général

Comment commander

AS32-3 - V F - H S

① ② ③ ④ ⑤

① Specification	② Clapet anti-retour	③ Matière	④ Support	⑤ Silencieux
MICRO: AS02-2 AX2.5-2 AT05-2	Nil -Sans clapet anti-retour	Nil -NBR F -FPM	Nil -Standard, Sans support H -Avec support	Nil - Standard, Sans silencieux
MINI: AS08-2/AS08-3 AX10-2/AX10-3 AP12-2/AP12-3 AD16-2	Nil -Sans clapet anti-retour V -Avec clapet anti-retour		Voir tableau 1	Nil - Standard, Sans silencieux S - Avec silencieux ZSC8
MIDI: AS32-2/AS32-3 AX40-2/AX40-3	Nil -Sans clapet anti-retour V -Avec clapet anti-retour			Nil - Standard, Sans silencieux S - Avec silencieux ZSC16

④ Choix du support (tableau 1)

Référence	Pour cartouche :	Référence	Pour cartouche :
HC	AS02-2 AX2.5-2 AT05-2	HD-2	AS32-2 AX40-2
HN-2	AS08-2 AX10-2 AP12-2 AD16-2	HD-3	AS32-3 AX40-3
HN-3	AS08-3 AX10-3 AP12-3		

Paramètres techniques

Référence	Pression (bar)	Vide max. (-kPa)	Débit aspiré (NL/min)	Air consommé (NL/min)	Poids (g)	Niveau sans silencieux (dB(A))	sonore	ø de tube recommandé	Pression (mm)	Vide (mm)
MICRO	AS02-2	4.0-6.0	75	16.9	8.0	0.6	70		2.5	4.0
	AX2.5-2	4.5-6.0	92	17.2	10.5	0.6	72		2.5	4.0
	AT05-2	4.0-6.0	85	19.5	21.5	0.6	78		2.5	4.0
MINI	AS08-2	4.0-6.0	75	46.0	27.0	2.3	62		4.0	6.0
	AS08-3	4.0-6.0	75	68.0	27.0	3.7	68		4.0	6.0
	AX10-2	4.5-6.0	94	44.0	34.5	2.3	78		4.0	6.0
	AX10-3	4.5-6.0	94	68.0	34.5	3.7	74		4.0	6.0
	AP12-2	1.7-4.0	90	42.0	33.0	2.3	68		4.0	6.0
	AP12-3	1.7-4.0	90	68.0	33.0	3.7	71		4.0	6.0
	AD16-2	6.0	73	40.0	46.0	2.0	77		4.0	6.0
	MIDI	AS32-2	4.0-6.0	75	178.0	130.0	14.3	82		6.0
	AS32-3	4.0-6.0	75	360.0	130.0	22.8	82		6.0	12.0
	AX40-2	4.5-6.0	95	170.0	135.0	14.3	89		6.0	12.0
	AX40-3	4.5-6.0	95	372.0	135.0	22.8	89		6.0	12.0

Débit d'aspiration (NL/min) à différentes dépressions (-kPa)

Référence	Pression (bar)	Air consommé (NL/min)	0	10	20	30	40	50	60	Vide maxi (-kPa)
AS02-2	4.0	6.0	14.2	8.1	5.2	3.8	2.2	-	-	57
	5.0	7.0	15.7	10.0	5.5	4.5	3.4	2.2	-	70
	6.0	8.0	16.9	12.2	6.3	4.6	3.9	3.0	2.0	75

Évaluation du temps (s/L) pour atteindre différentes dépressions (-kPa)

Référence	Pression (bar)	Air consommé (NL/min)	10	20	30	40	50	60	70	Vide maxi (-kPa)
AS02-2	4.0	6.0	0.37	1.41	2.8	5.1	-	-	-	57
	5.0	7.0	0.35	1.2	2.5	4.1	6.6	11.1	-	70
	6.0	8.0	0.34	1.1	2.4	4.1	6.2	9.0	14.3	75

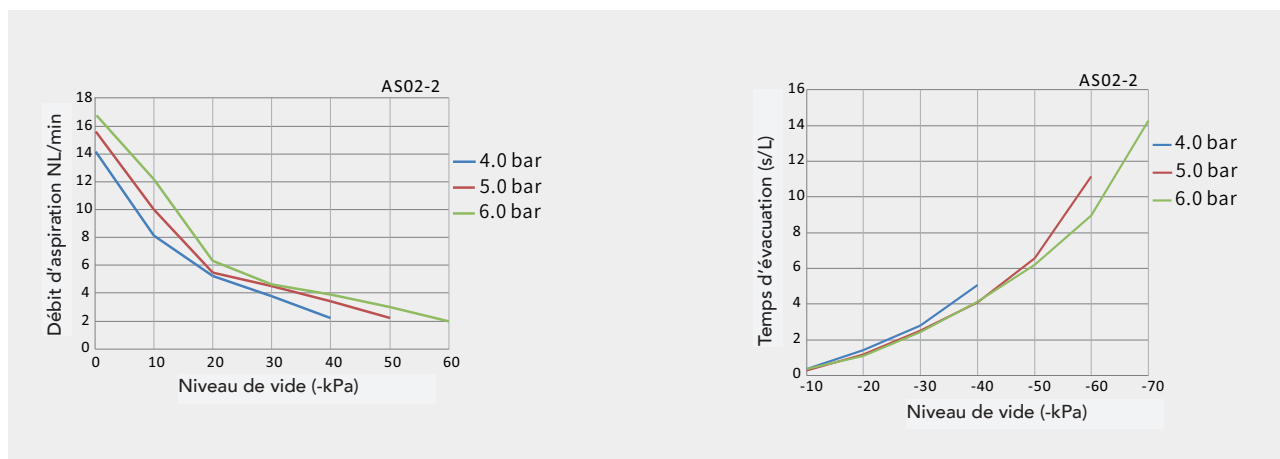

Débit d'aspiration (NL/min) à différentes dépressions (-kPa)

Référence	Pression (bar)	Air consommé (NL/min)	0	10	20	30	40	50	60	Vide maxi (-kPa)
AX2.5-2	4.5	9.0	14.9	9.9	4.8	4.1	3.3	2.6	1.7	89
	5.0	9.5	15.6	11.6	6.6	4.0	3.3	2.6	1.7	91
	6.0	10.5	17.2	14.2	9.3	4.5	3.3	2.3	1.4	90

Évaluation du temps (s/L) pour atteindre différentes dépressions (-kPa)

Référence	Pression (bar)	Air consommé (NL/min)	10	20	30	40	50	60	70	80	Vide maxi (-kPa)
AX2.5-2	4.5	9.0	0.4	1.3	3.2	4.6	6.5	9.8	15.3	25.70	89
	5.0	9.5	0.3	0.9	2.4	4.3	6.7	9.5	14.1	22.03	91
	6.0	10.5	0.2	0.7	1.7	3.7	5.9	9.5	14.5	22.41	90

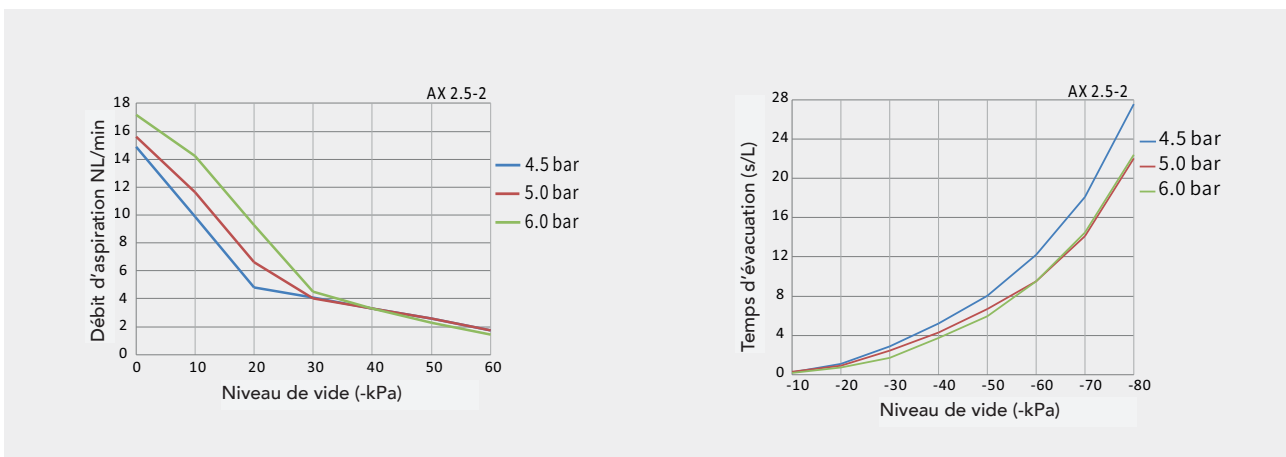

Débit d'aspiration (NL/min) à différentes dépressions (-kPa)

Référence	Pression (bar)	Air consommé (NL/min)	0	10	20	30	40	50	60	70	Vide maxi (-kPa)
AT05-2	4.0	16.0	19.5	17.7	13.5	9.0	6.1	5.0	3.3	1.8	84
	6.0	21.5	18.7	17.4	15.1	13.1	9.7	6.0	2.7	1.8	75

Évaluation du temps (s/L) pour atteindre différentes dépressions (-kPa)

Référence	Pression (bar)	Air consommé (NL/min)	10	20	30	40	50	60	70	80	Vide maxi (-kPa)
AT05-2	4.0	16.0	0.2	0.5	1.1	2.2	3.4	5.2	9.0	17.36	84
	6.0	21.5	0.2	0.5	0.9	1.5	2.6	4.7	7.7	16.09	75

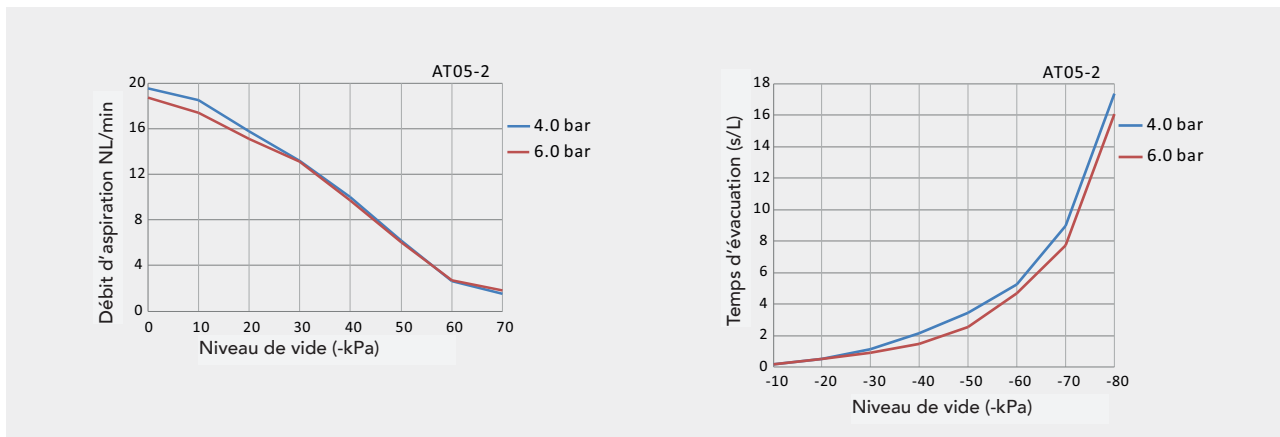

Débit d'aspiration (NL/min) à différentes dépressions (-kPa)

Référence	Pression (bar)	Air consommé (NL/min)	0	10	20	30	40	50	60	70	Vide maxi (-kPa)
AS08-2	4.0	19.0	44.0	34.0	22.6	14.4	10.8	6.4	-	-	60
	5.0	23.0	46.0	40.0	28.5	17.3	12.8	9.5	6.1	-	70
	6.0	27.0	46.0	42.0	32.6	22.6	12.0	9.8	8.3	5.9	75
AS08-3	4.0	19.0	60.0	38.0	24.0	14.9	11.5	6.8	-	-	60
	5.0	23.0	66.0	40.0	32.0	19.1	13.3	9.9	6.5	-	70
	6.0	27.0	68.0	42.0	36.0	24.0	13.0	10.2	8.4	6.3	75

Évaluation du temps (s/L) pour atteindre différentes dépressions (-kPa)

Référence	Pression (bar)	Air consommé (NL/min)	10	20	30	40	50	60	70	Vide maxi (-kPa)
AS08-2	4.0	19.0	0.07	0.25	0.56	1.02	1.89	5.24	-	60
	5.0	23.0	0.07	0.22	0.47	0.85	1.53	2.40	6.43	70
	6.0	27.0	0.07	0.20	0.39	0.74	1.35	2.14	3.35	75
AS08-3	4.0	19.0	0.06	0.22	0.53	0.93	1.72	4.61	-	60
	5.0	23.0	0.06	0.19	0.44	0.83	1.35	2.23	6.33	70
	6.0	27.0	0.05	0.19	0.38	0.68	1.26	2.08	3.05	75

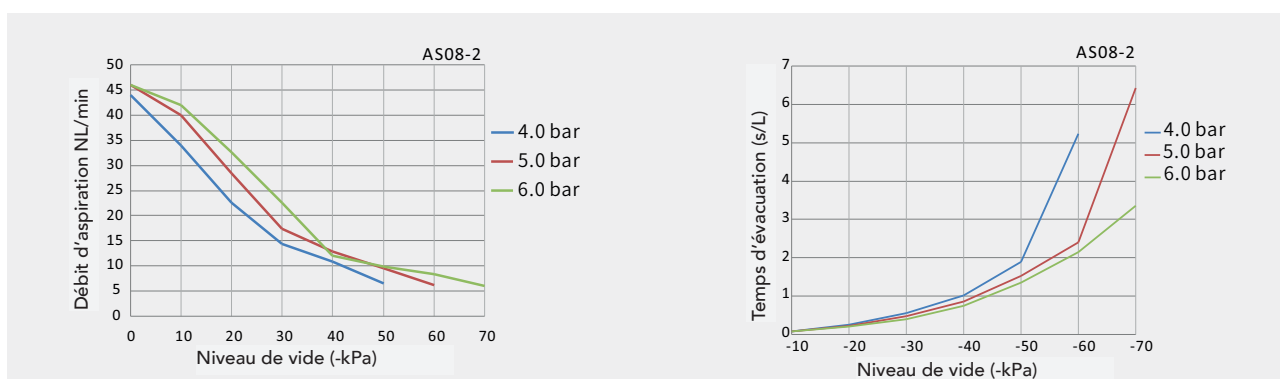

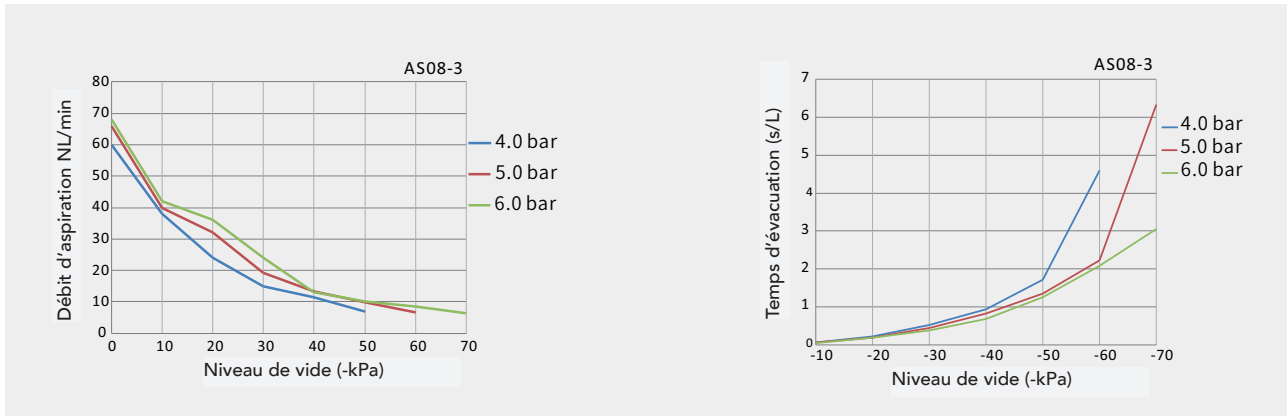

Débit d'aspiration (NL/min) à différentes dépressions (-kPa)

Référence	Pression (bar)	Air consommé (NL/min)	0	10	20	30	40	50	60	70	80	Vide maxi (-kPa)
AX10-2	4.5	27.5	44.0	40.0	28.4	18.8	10.7	9.4	6.9	4.6	2.3	91
	5.0	30.0	44.0	40.0	30.6	22.2	13.5	8.9	6.6	4.5	2.0	94
	6.0	34.5	42.0	40.0	33.0	26.9	18.7	9.4	6.2	4.6	1.4	93
AX10-3	4.5	27.5	64.0	40.0	32.0	18.0	11.3	9.7	7.3	4.9	2.7	91
	5.0	30.0	66.0	40.0	34.0	24.0	14.3	9.3	6.9	4.8	2.4	94
	6.0	34.5	68.0	44.0	34.0	30.0	20.0	10.5	6.5	4.9	1.7	93

Évaluation du temps (s/L) pour atteindre différentes dépressions (-kPa)

Référence	Pression (bar)	Air consommé (NL/min)	10	20	30	40	50	60	70	80	Vide maxi (-kPa)
AX10-2	4.5	27.5	0.11	0.27	0.52	0.98	1.65	2.41	3.87	6.20	91
	5.0	30.0	0.12	0.27	0.48	0.83	1.49	2.49	3.77	6.19	94
	6.0	34.5	0.12	0.26	0.45	0.72	1.21	2.33	3.68	6.35	93
AX10-3	4.5	27.5	0.06	0.19	0.40	0.76	1.45	2.21	3.49	5.55	91
	5.0	30.0	0.05	0.19	0.37	0.66	1.26	2.14	3.45	5.60	94
	6.0	34.5	0.05	0.18	0.35	0.59	1.02	2.10	3.31	5.72	93

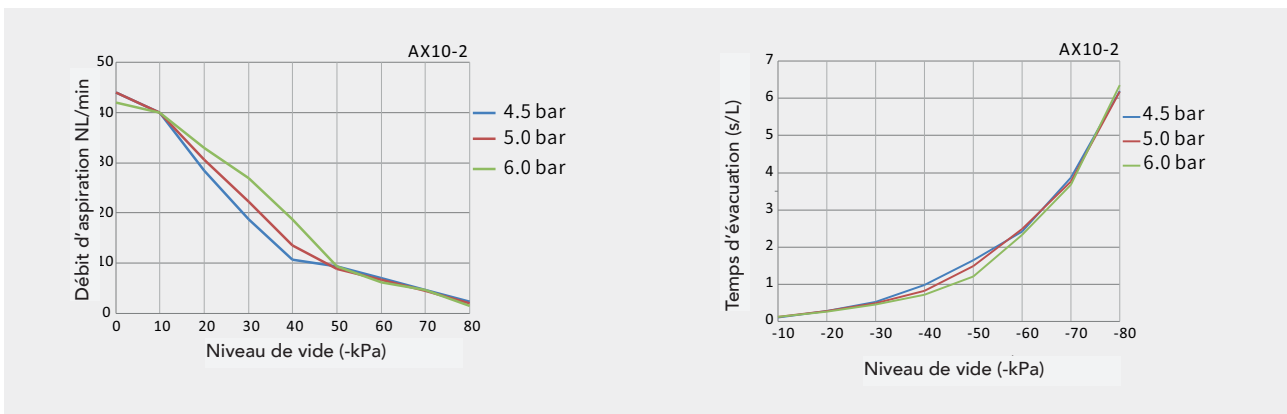

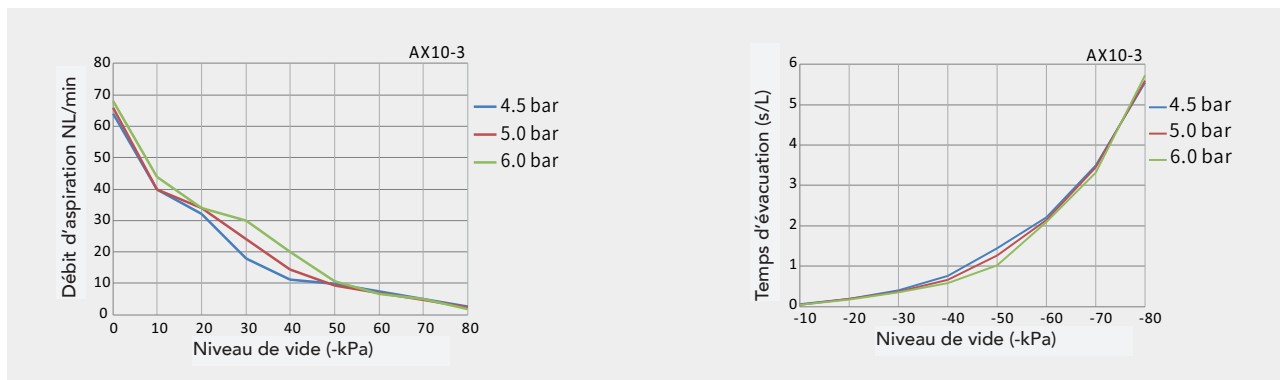

Débit d'aspiration (NL/min) à différentes dépressions (-kPa)

Référence	Pression (bar)	Air consommé (NL/min)	0	10	20	30	40	50	60	70	80	Vide maxi (-kPa)
AP12-2	1.7	19.0	36.0	19.0	10.5	6.6	2.8	-	-	-	-	43
	2.2	22.5	38.0	28.0	15.5	11.0	7.7	3.8	-	-	-	58
	3.14	29.0	42.0	36.0	25.6	14.9	10.4	8.9	6.6	4.2	1.9	90
	4.0	33.0	42.0	38.0	30.0	23.0	15.0	8.0	5.9	4.3	1.1	88
AP12-3	1.7	19.0	46.0	19.8	10.5	7.0	3.0	-	-	-	-	43
	2.2	22.5	52.0	30.0	12.0	8.2	5.8	2.7	-	-	-	58
	3.14	29.0	62.0	38.0	28.0	10.0	7.7	6.7	4.8	2.9	1.4	90
	4.0	33.0	68.0	40.0	34.0	24.0	11.4	5.7	4.2	3.0	1.2	88

Évaluation du temps (s/L) pour atteindre différentes dépressions (-kPa)

Référence	Pression (bar)	Air consommé (NL/min)	10	20	30	40	50	60	70	80	Vide maxi (-kPa)
AP12-2	1.7	19.0	0.15	0.55	1.26	2.90	-	-	-	-	43
	2.2	22.5	0.14	0.37	0.88	1.58	2.78	-	-	-	58
	3.14	29.0	0.12	0.29	0.59	1.07	1.86	2.66	4.33	6.72	90
	4.0	33.0	0.12	0.26	0.49	0.77	1.50	2.48	3.98	7.05	88
AP12-3	1.7	19.0	0.13	0.52	1.22	2.75	-	-	-	-	43
	2.2	22.5	0.08	0.31	0.70	1.33	2.54	-	-	-	58
	3.14	29.0	0.06	0.21	0.45	0.94	1.58	2.40	3.83	6.07	90
	4.0	33.0	0.06	0.21	0.38	0.67	1.26	2.36	3.75	6.57	88

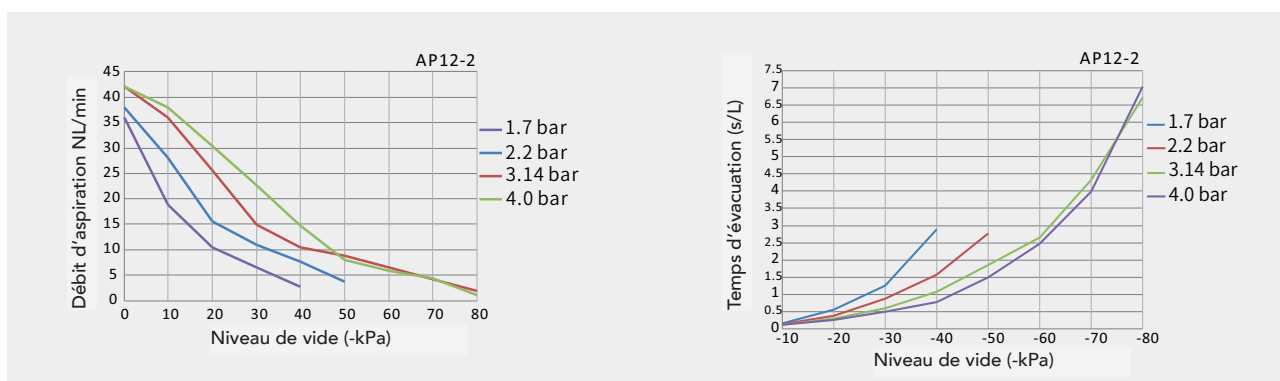

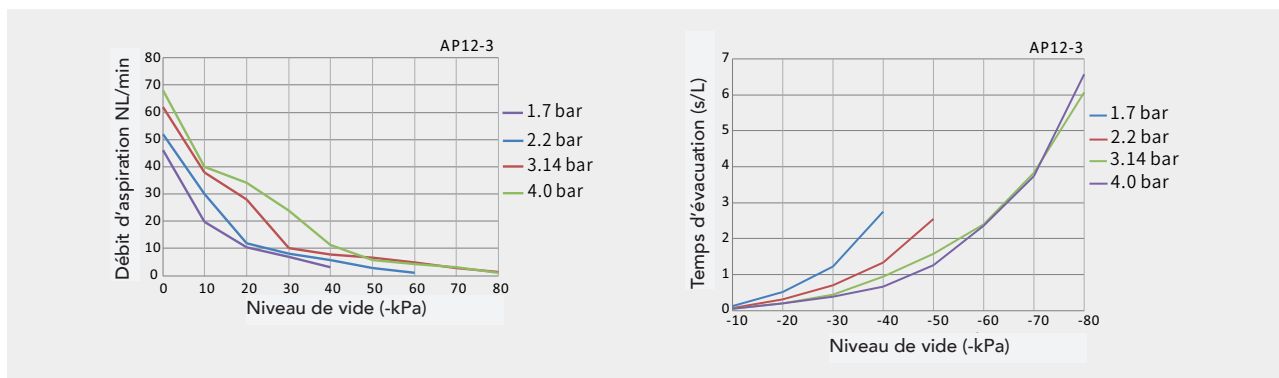

Débit d'aspiration (NL/min) à différentes dépressions (-kPa)

Référence	Pression (bar)	Air consommé (NL/min)	0	10	20	30	40	50	60	70	Vide maxi (-kPa)
AD16-2	6	46.0	40.0	38.0	30.5	26.7	22.0	17.0	12.0	3.5	72

Évaluation du temps (s/L) pour atteindre différentes dépressions (-kPa)

Référence	Pression (bar)	Air consommé (NL/min)	10	20	30	40	50	60	70	Vide maxi (-kPa)
AD16-2	6	46.0	0.04	0.18	0.39	0.62	0.95	1.47	3.10	72

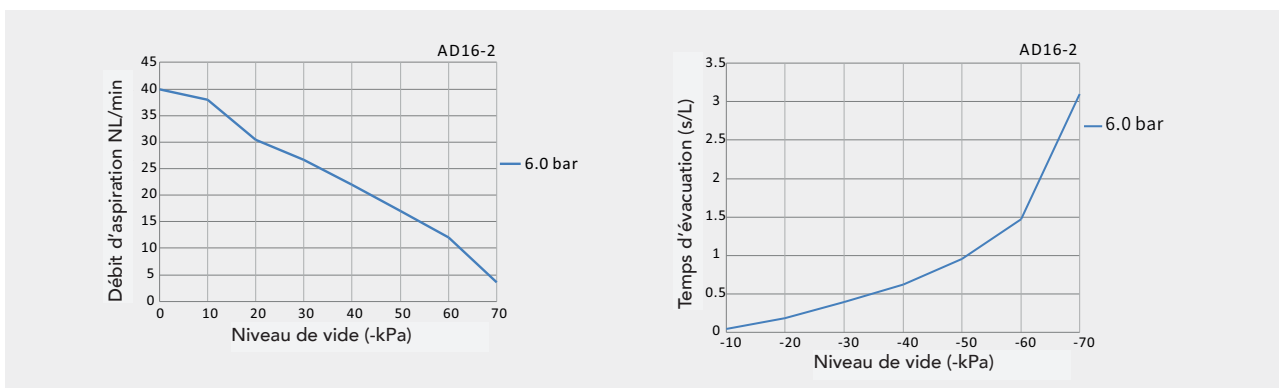

Débit d'aspiration (NL/min) à différentes dépressions (-kPa)

Référence	Pression (bar)	Air consommé (NL/min)	0	10	20	30	40	50	60	70	Vide maxi (-kPa)
AS32-2	4.0	120.0	172.0	136.0	92.0	60.0	44.0	26.2	10.5	-	60
	5.0	125.0	180.0	156.0	116.0	72.0	48.0	36.0	26.9	12.8	70
	6.0	130.0	178.0	164.0	134.0	94.0	50.0	38.0	32.0	18.3	75
AS32-3	4.0	120.0	350.0	152.0	110.0	64.0	50.0	26.7	11.5	-	60
	5.0	125.0	370.0	185.0	125.0	90.0	50.0	36.2	27.3	13.9	70
	6.0	130.0	390.0	210.0	135.0	100.0	65.0	35.1	30.3	18.3	75

Évaluation du temps (s/L) pour atteindre différentes dépressions (-kPa)

Référence	Pression (bar)	Air consommé (NL/min)	10	20	30	40	50	60	70	Vide maxi (-kPa)
AS32-2	4.0	120.0	0.04	0.08	0.16	0.27	0.47	0.98	-	60
	5.0	125.0	0.04	0.08	0.14	0.25	0.39	0.63	1.17	70
	6.0	130.0	0.04	0.08	0.13	0.21	0.36	0.55	0.86	75
AS32-3	4.0	120.0	0.03	0.08	0.15	0.26	0.44	0.94	-	60
	5.0	125.0	0.03	0.07	0.13	0.23	0.38	0.61	1.07	70
	6.0	130.0	0.03	0.05	0.10	0.18	0.36	0.56	0.87	75

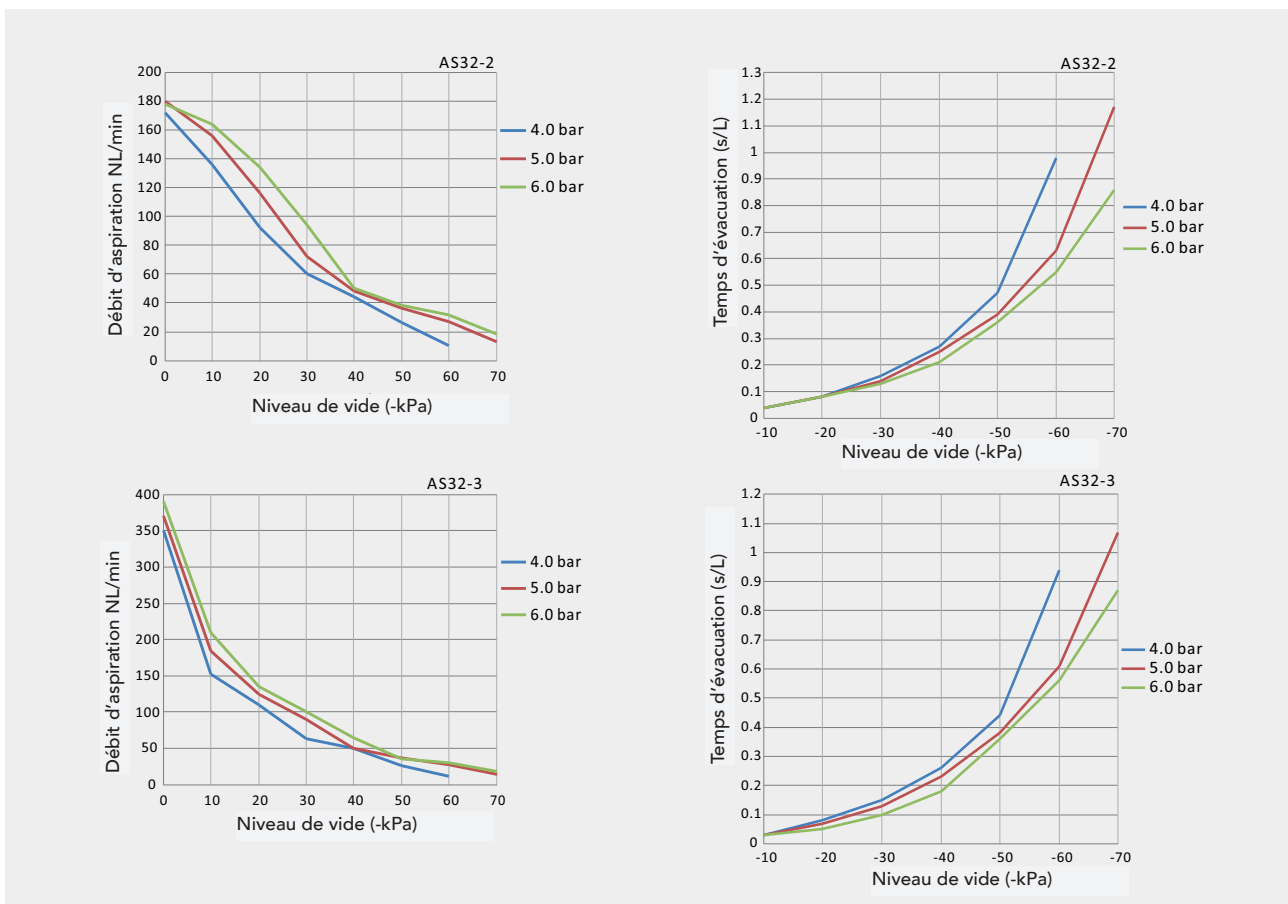

Débit d'aspiration (NL/min) à différentes dépressions (-kPa)

Référence	Pression (bar)	Air consommé (NL/min)	0	10	20	30	40	50	60	70	80	90	Vide maxi (-kPa)
AX40-2	4.5	120.0	170.0	136.0	100.0	58.0	40.0	36.0	25.0	17.8	11.7	3.1	91
	5.0	125.0	170.0	140.0	106.0	74.0	46.0	34.0	24.0	17.6	10.8	2.9	95
	6.0	135.0	162.0	142.0	116.0	92.0	68.0	40.0	22.5	17.8	9.4	2.3	94
AX40-3	4.5	120.0	350.0	175.0	120.0	80.0	44.0	32.7	24.5	17.8	11.6	3.2	91
	5.0	125.0	360.0	190.0	125.0	95.0	65.0	36.0	26.0	17.6	10.8	2.8	95
	6.0	135.0	380.0	220.0	130.0	105.0	90.0	54.0	26.0	17.8	9.3	2.2	94

Évaluation du temps (s/L) pour atteindre différentes dépressions (-kPa)

Référence	Pression (bar)	Air consommé (NL/min)	10	20	30	40	50	60	70	80	90	Vide maxi (-kPa)
AX40-2	4.5	120.0	0.04	0.08	0.15	0.28	0.46	0.66	0.99	1.51	-	91
	5.0	125.0	0.04	0.08	0.14	0.24	0.41	0.66	1.02	1.52	3.27	95
	6.0	135.0	0.04	0.08	0.14	0.20	0.30	0.57	0.95	1.55	3.70	94
AX40-3	4.5	120.0	0.03	0.07	0.13	0.23	0.38	0.63	0.97	1.50	3.25	91
	5.0	125.0	0.03	0.07	0.14	0.21	0.37	0.62	0.99	1.46	3.23	95
	6.0	135.0	0.03	0.05	0.10	0.16	0.27	0.47	0.86	1.45	3.92	94

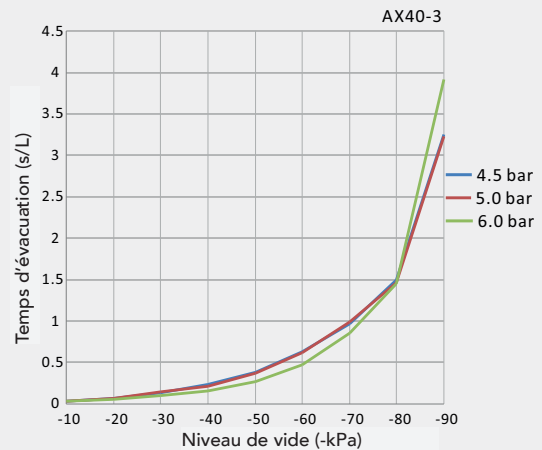
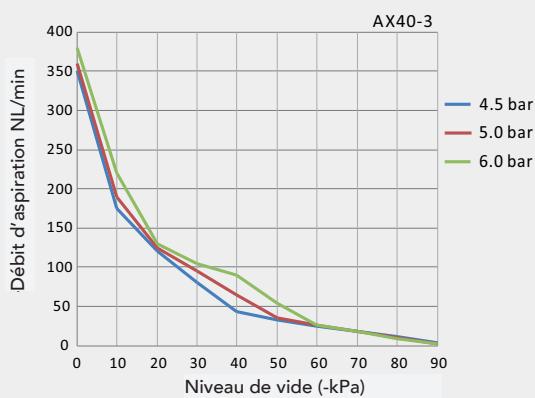
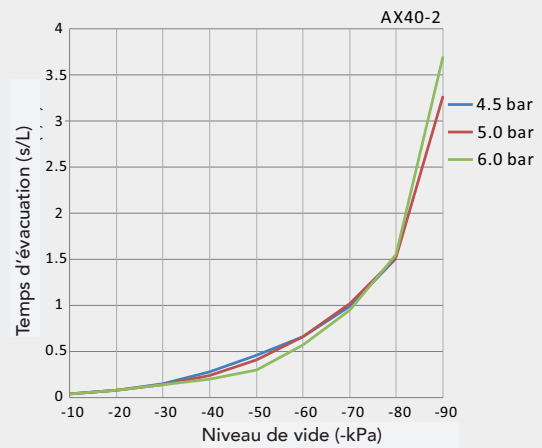
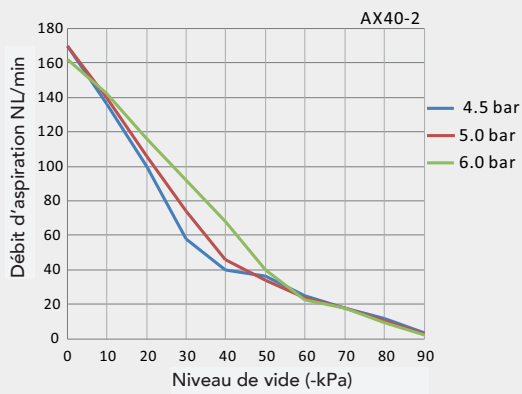

Dimensions (mm)

AS02-2
AX2.5-2
AT05-2

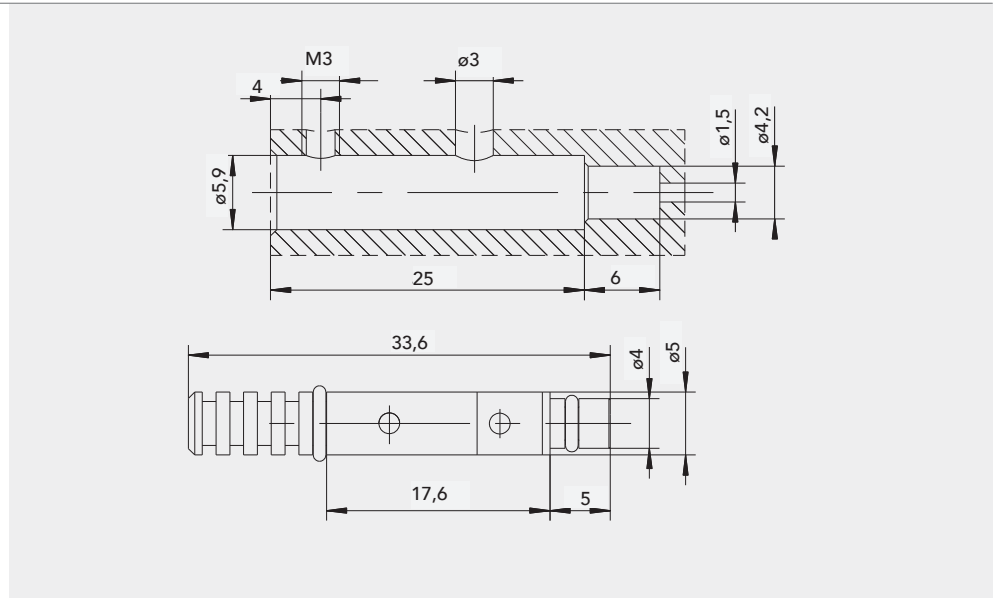

AS02-2-H
AX2.5-2-H
AT05-2-H

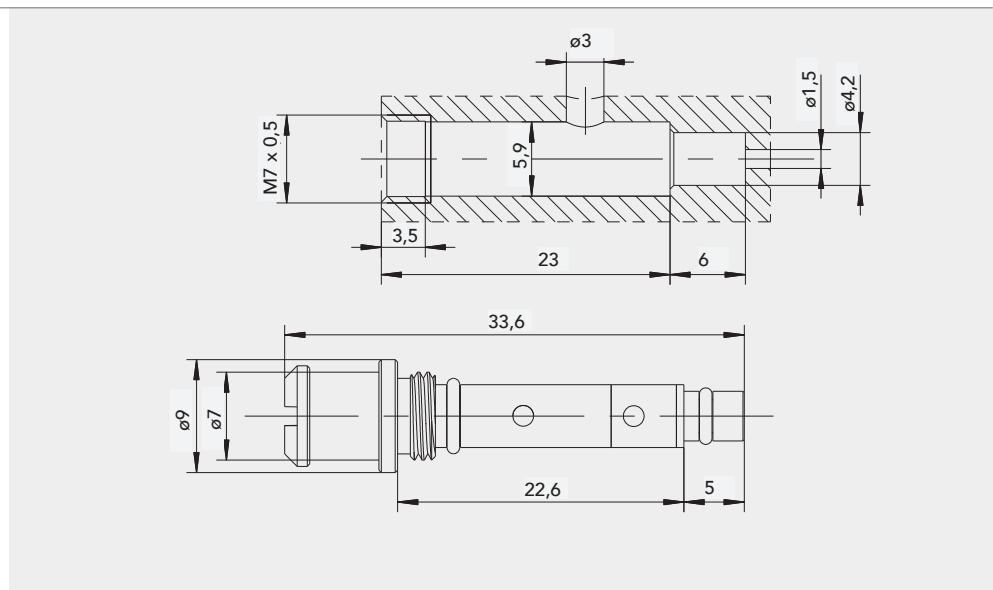

AS08-2
AX10-2
AP12-2
AD16-2

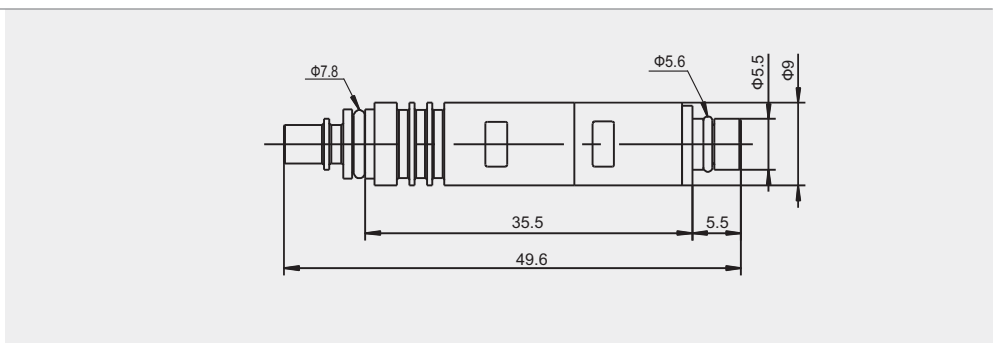

Dimensions (mm)

AS08-2-H
 AX10-2-H
 AP12-2-H
 AD16-2-H

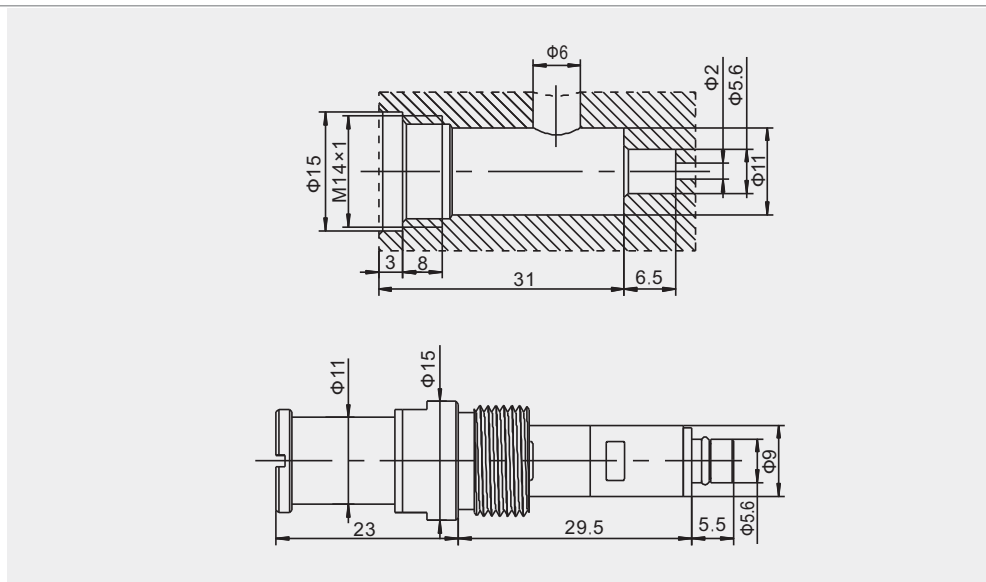

AS08-3
 AX10-3
 AP12-3

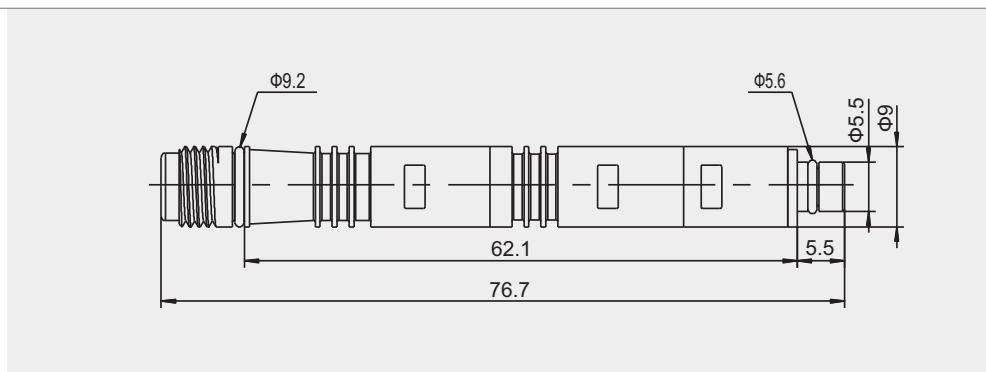

AS08-3-H
 AX10-3-H
 AP12-3-H

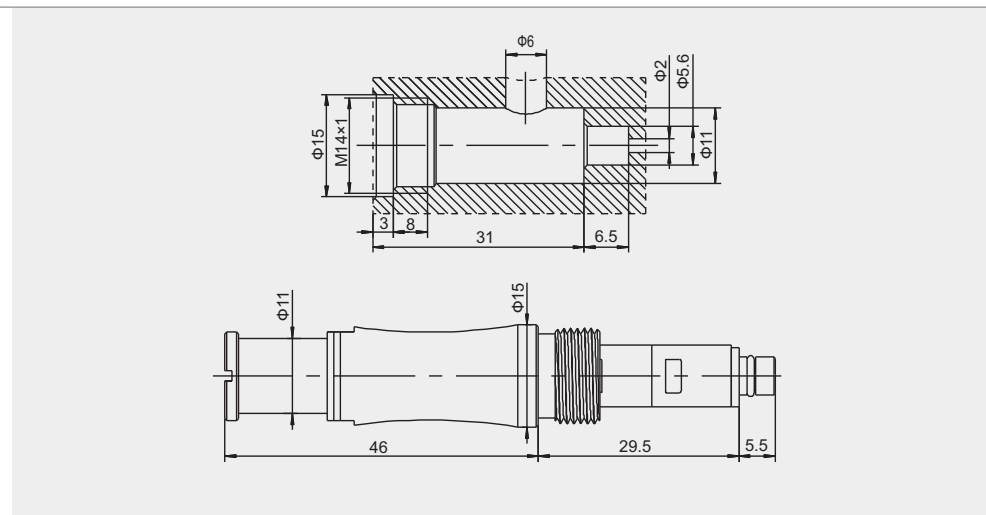

Dimensions (mm)

AS32-2
AX40-2

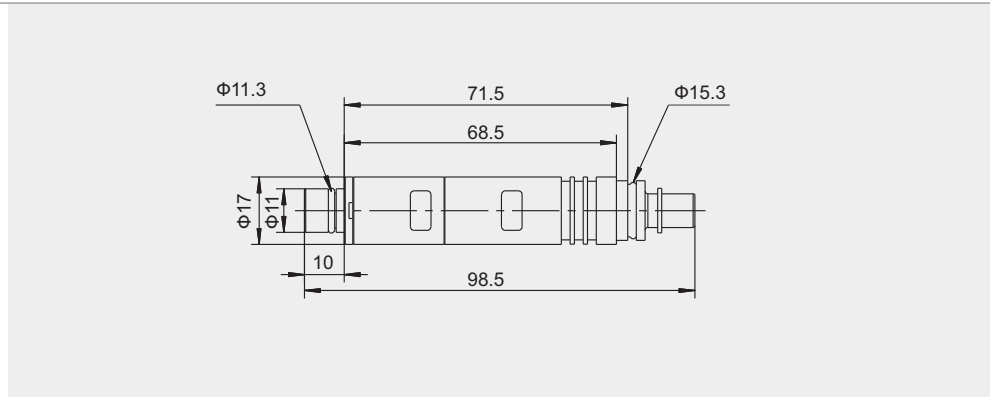

AS32-2-H
AX40-2-H

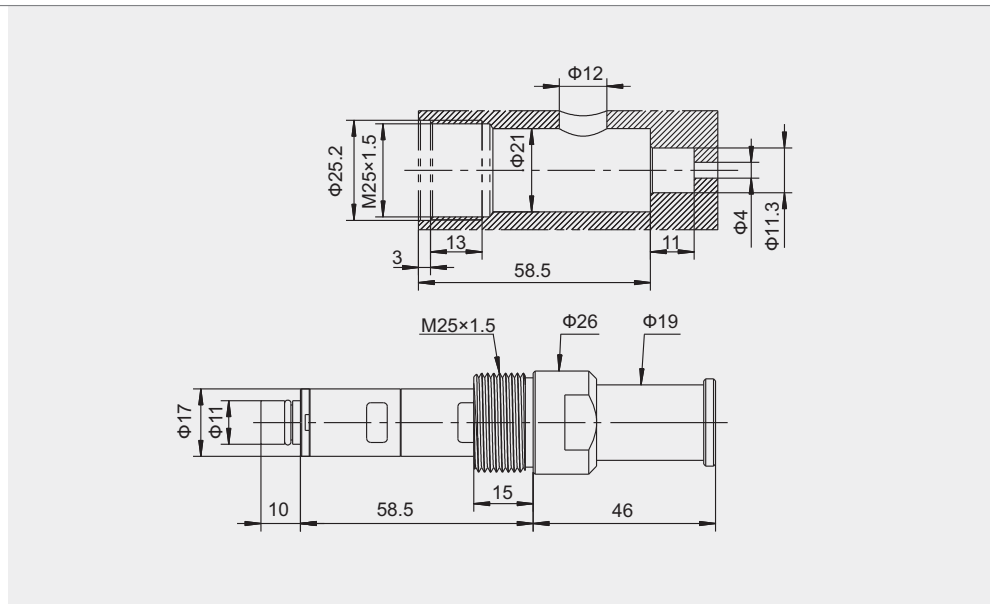

AS32-3
AX40-3

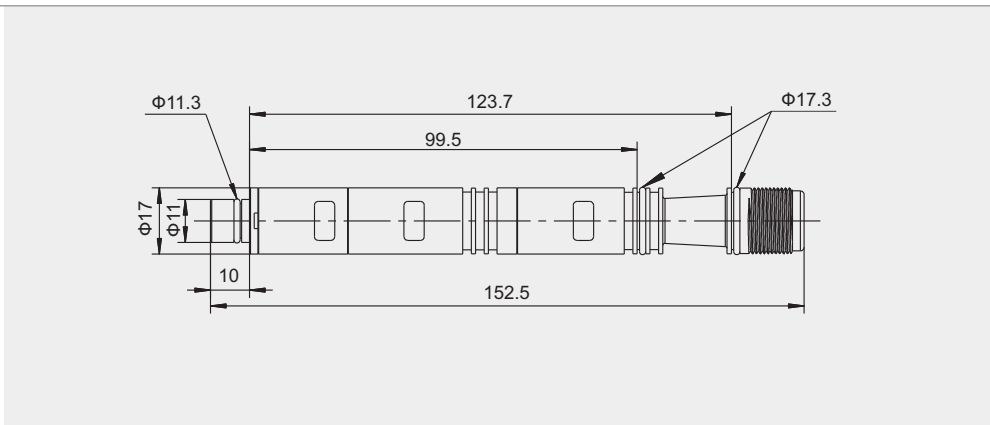

Dimensions (mm)

AS32-3-H

AX40-3-H

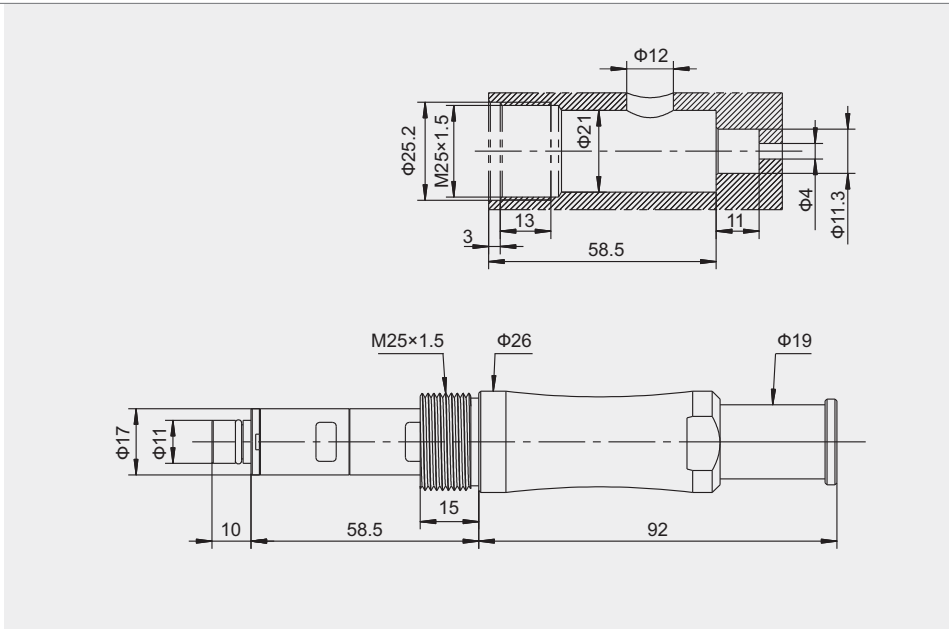

Silencieux ZSC8



montage sur support
HN-2 et HN-3

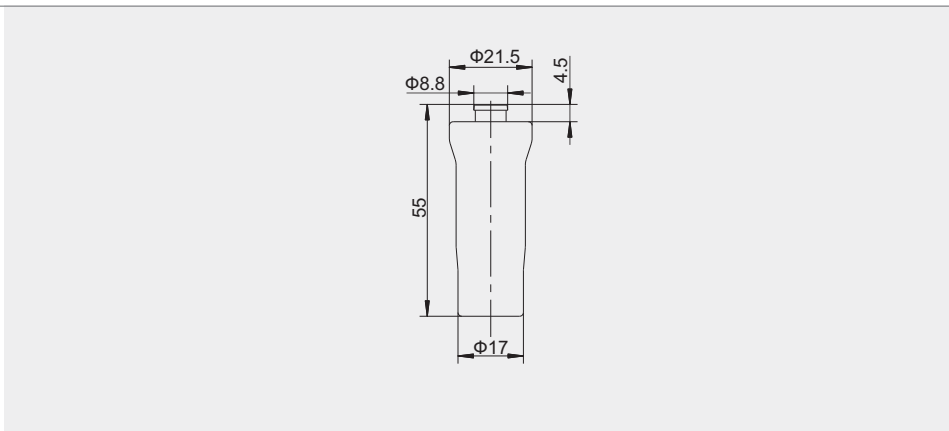

Silencieux ZSC16



montage sur support
HD-2 et HD-3

